

SPÜLTECHNIK ZEICHNUNGEN

ecomax™
by **HOBART**

Modell **G404** Gläserspülmaschine

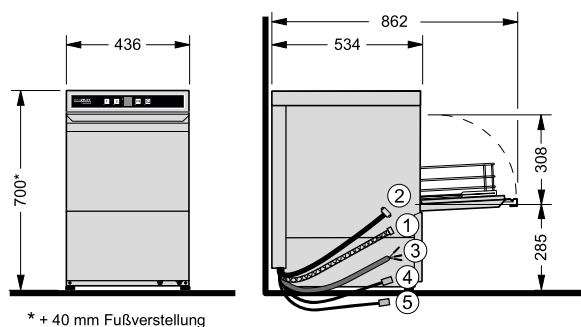

ecomax plus
by **HOBART**

Modell **G415** Gläserspülmaschine

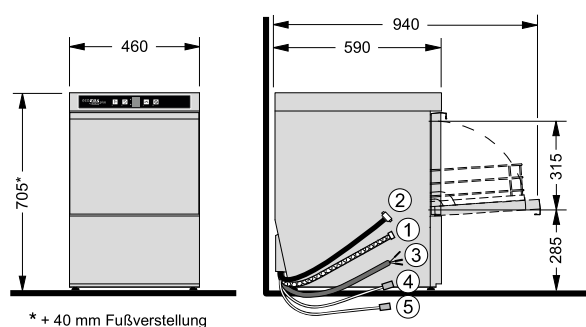

Modell **F504** Geschirrspülmaschine

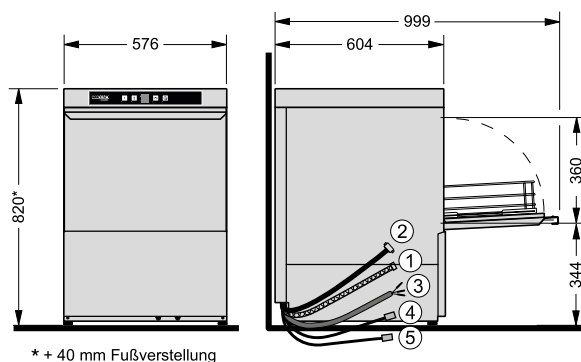

Modell **F515** Geschirrspülmaschine

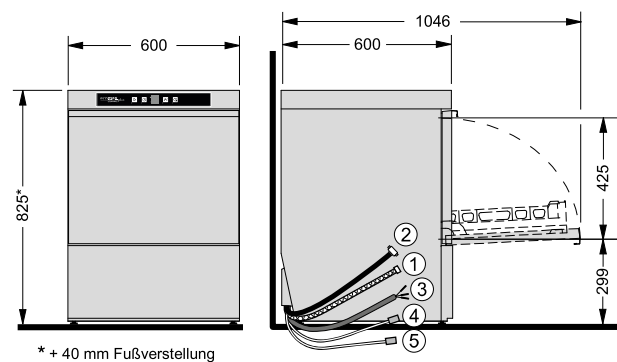

Modell **H604** Haubenspülmaschine

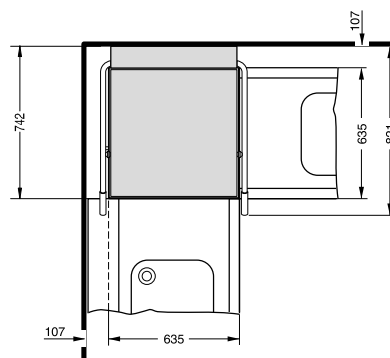
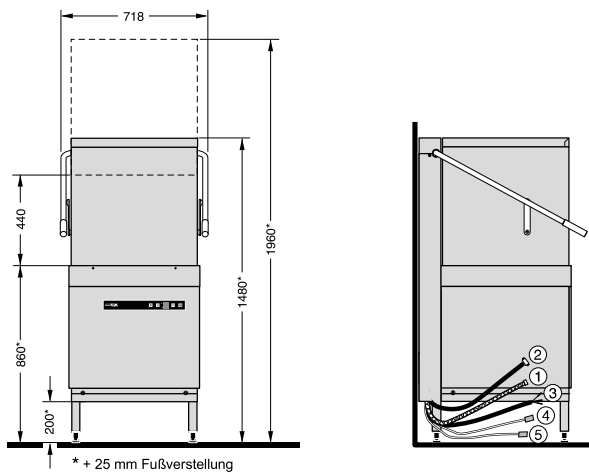

plus

- ① Ablaufschlauch
- ② Zulaufschlauch
- ③ Anschlusskabel
- ④ Flüssigreiniger^{a)}
- ⑤ Klarspüler^{a)}

^{a)} bei Maschinen mit Schlauchbefüllung